

P.C.B LAYOUT
TOP VIEW

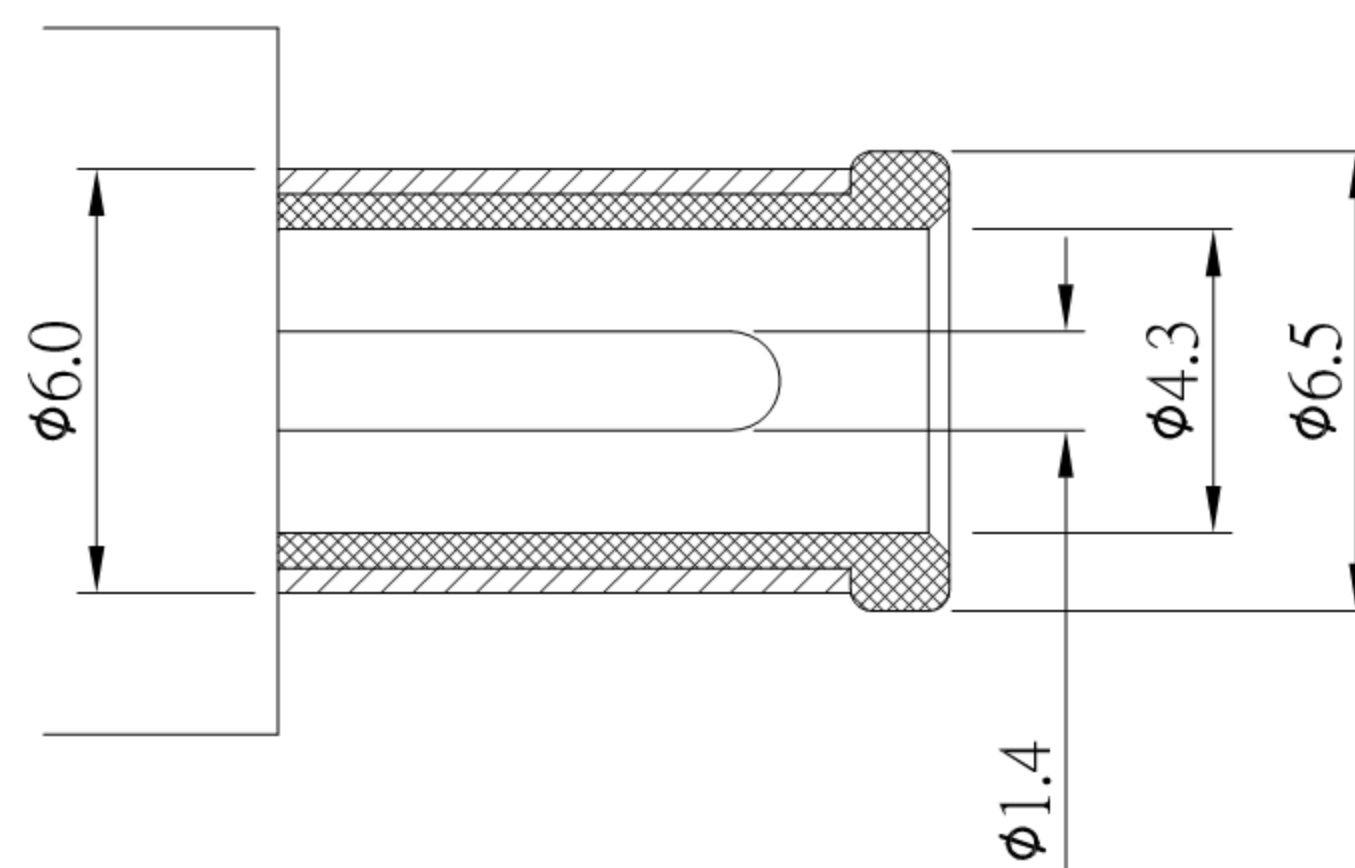
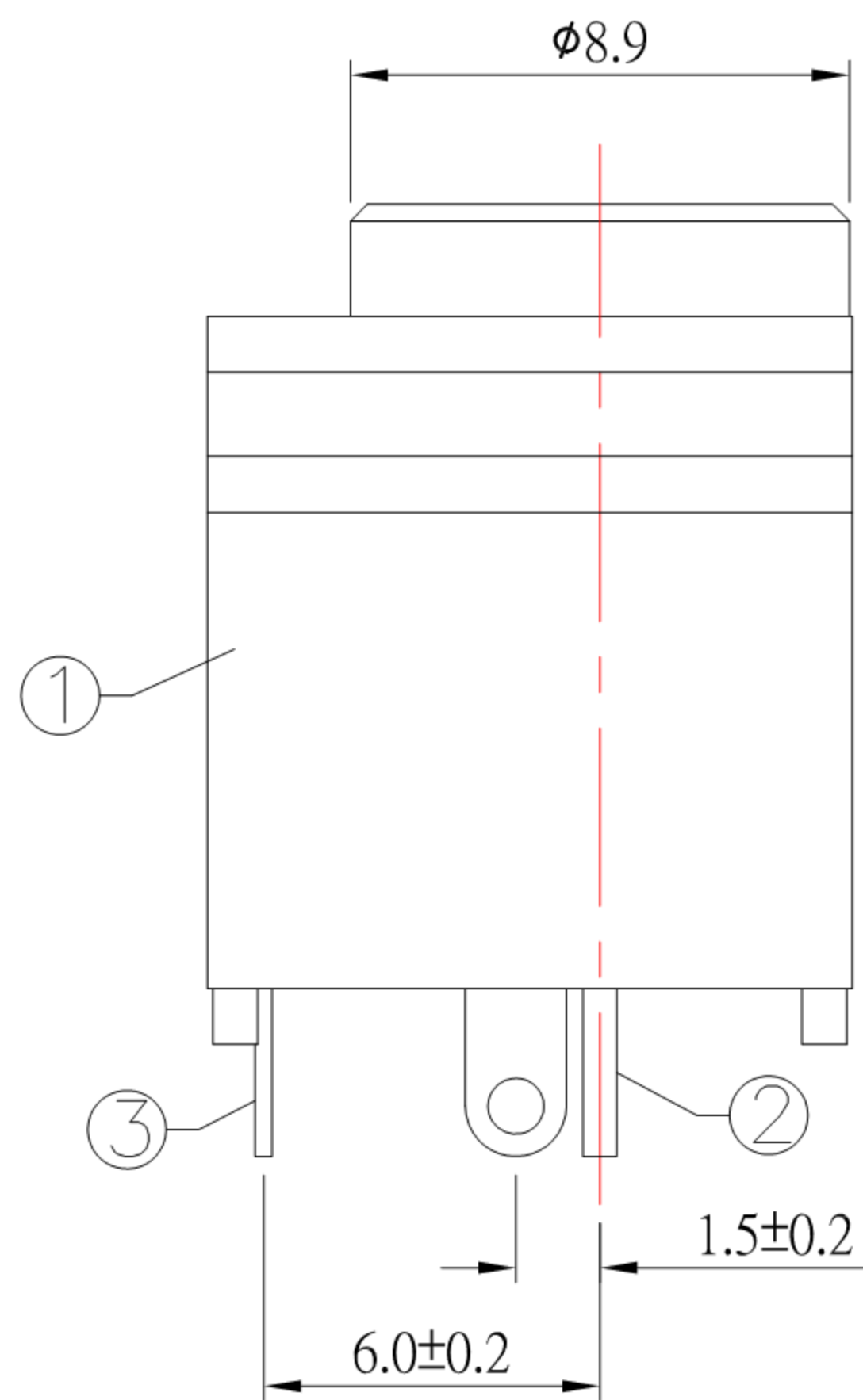

DC MATE PLUG

MODEL NO.	DC-D037-1.4
SCHEMATIC	

SPECIFICATION

1. Rating : DC 30V, 2.0A ;
2. Contact resistance : $\leq 30m\Omega$;
3. Insulation resistance : $\geq 100M\Omega$;
4. Withstand voltage : 500VAC ;
5. Insertion and extraction force : 3-20N;
6. life test : 5,000 cycles °

NO.	DESCRIPTION	QTY	MATERIAL	PLATING
④	CONTACT FOOT	1	BRASS	Ag-Plating
③	SPRING	1	PHOSPHOR BRONZE	Ag-Plating
②	CURVE PIECE	1	PHOSPHOR BRONZE	Ag-Plating
①	HOUSING	1	PA9T	



东莞市高迪电子有限公司
Dong Guan KDRR Electronic Switch Jack Co., Ltd.

TOLERANCE UNLESS OTHERWISE STATED :
 Up to 5 ±0.2
 Above 5 ~ 15 ±0.3
 Above 15 ~ 30 ±0.4
 Above 30 ~ 50 ±0.5
 Angle ±0.3°

3RD. ANGEL'S

UNITS MM

DRAWN BY:	DATE	MAT'L	TITLE	JACK
Jack Lu	01/22/18		MODLE	DC JACK
CHECKED BY:	DATE	FINISH	DWG NO.	DC-D037-1.4-S124
Jacky Chen	01/22/18		PART NO.	DC-D037-1.4-S124
APPROVED BY:	DATE	SCALE	SHEET NO.	1 of 1
Tony Kao	01/22/18	1 : 1		

ITEM NO.	DESCRIPTION	DRAWN	DATE
1	更新PCB LAYOUT	Jack	012218

SIZE A4
VER R1